



Loren Cook Roof Curbs

Technical Product Information

CURB O.D. 22-1/2" x 22-1/2"

P.O. NUMBER _____

CUSTOMER _____

PROJECT _____

LOCATION _____

ARCHITECT _____

STANDARD CONSTRUCTION

- 18 GAUGE GALVANIZED STEEL
- 1-1/2", 3LB. DENSITY FIBERGLASS INSULATION
- WOOD NAILER FLUSH
- UNITIZED CONSTRUCTION
- CONTINUOUS WELDED CORNER SEAMS

FITS

- | | | | | |
|-----------|--------------|-------------|---------------|------------|
| • 150 C | • 165 SCX | • 150 TLC-B | • 150 LPD | • 14 CVR |
| • 165 C | • 150 V | • 165 TLC-D | • 150 LPB | • 14 CVR-S |
| • 150 R | • 150 VH | • 165 TLC-B | • 165 LPD | • 16 UCV |
| • 150 RH | • 165 V | • 150 HLC-D | • 165 LPB | • 16 CVR |
| • 165 R | • 165 VH | • 150 HLC-B | • 120 QMXE | • 16 CVR-S |
| • 165 RH | • 165 VX | • 165 HLC-D | • 120 QMXS | |
| • 165 RX | • 150 SRSH-D | • 165 HLC-B | • 120 QMXE-HP | |
| • 150 SC | • 150 SRSH-B | • 120 LPD | • 120 QMXS-HP | |
| • 150 SCH | • 165 SRSH-D | • 120 LPB | • 120 QMXU | |
| • 165 SC | • 165 SRSH-B | • 135 LPD | • 120 QMXU-HP | |
| • 165 SCH | • 150 TLC-D | • 135 LPB | • 14 UCV | |

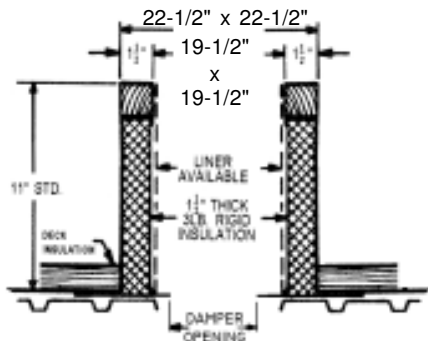

RC-2A

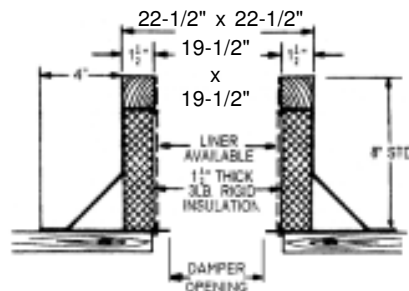

RC-3A

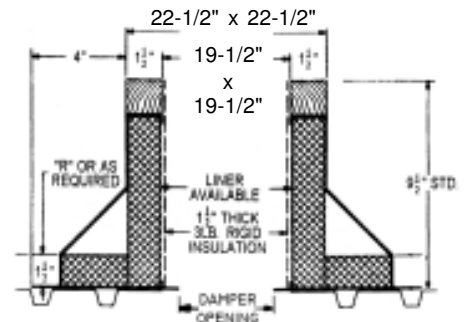

RC-4A

PROJECT REQUIREMENTS

QTY.	STYLE	* OVERALL HEIGHT	"R" DIM.	PITCH REQUIREMENTS		DAMPER OPENING	TAG
				LONG SIDE	SHORT SIDE		